

VOLKSLIFT

Function table

功能表

Standard function

标准功能

无呼自返基站功能 Automatic return to main floor	警铃 Alarm bell
设置厅、轿门时间 Separate car and hall call door times	光幕门保护装置 Light curtain
关门时间保护 Door closing overtime protection	误登陆取消 Cancel error log
开、关门按钮 Door open & close button	驻停 Parking operation
紧急消防操作 Emergency firemen operation	两台并联 (V500控制系统为选配) Parallel operation
轿内紧急照明 Emergency car light	驱动设备过热保护 Motor temperature protection
全集选控制 Full collective operation	消防信号反馈 Fire signal feedback
厅和轿厢数字式位置指示器 Hall & car position indicator	防捣乱操作 Anti-nuisance function
厅和轿厢呼梯/登记 Hall & car call register	轿厢到站钟 Car arrival chime
厅及轿厢运行方向显示 Hall & car direction indicator	自动开关门 Automatic open shut
监控室与机房、轿厢对讲 (不含机房到监控室连线) Intercom between security room and car/machine room	撞底缓冲装置 Buffer
独立服务 Independent running	门区外不能开门 Non-open outside door zone
满载不停梯 Load non stop	预转矩输出 Pre-torque output
超载不启动(警示灯及蜂鸣器) Overload warning	电网电压波动检测功能 Voltage wave detection
运行次数显示功能 Trip counter	接触器反馈检测功能 Contactor detection
轿顶与控制柜紧急电动运行 Top of car inspection & machine room inspection	继电器检查保护 Relay detection
轿内通风手动及照明自动控制功能 Ventilation manual and lighting automatic control	速度反馈检测功能 Speed detection
故障自动检测功能 Faulty automatic detection	故障低速自救功能 Self-rescue leveling running

Standard function 标准功能

反向指令自动消除 Reverse cancelling	安全回路保护 Safety circuit protection
本层外召唤门 Open the door outside this hall	限位保护 Limit switch protection
外召按钮嵌入自诊断 Call conglutination judgment	上下极限保护装置 Upper limit protection device
重复关门 Repetition of door closing	门连锁保护 Protection of door-lock disconnect when running
不停层设置 Stop layer settings	运行接触器保护 Running contactor protection
待梯层设定 Main floor settings	抱闸检测保护 Brake detection
楼层显示字符的任意设定 Floor display any set of characters	手动松闸救援 Manual rescue
输入口干扰评价 Evaluation of input disturbance	端站换速及楼层号校正 Forced deceleration
井道自学习 Shaft parameters self-tuning	手动选层 Select floor in the controler
逆向运行保护 Protection of reverse travel	机房开关门 Operating the door C/O in the controler
防打滑保护 Anti-slip protection	

Optional function 选择功能

停电应急救援 Emergency rescue running	读卡器 IC card user management
有司机操作 Attendant operation	BA接口 (干接点) BA access
CCTV电缆 (轿厢到机房) CCTV cable (car to machine room)	小区监视盘 Supervisory panel
紧急备用电源操作装置 Emergency power operation	小区电脑监视 PC supervisory
消防员服务 (轿厢内) Firemen operation (in car)	提前开门 Running-open
开门再平层 Re-leveling when the door is open	群控管理运行 Group control adjustment operation
电梯远程监控 Tele-monitoring	液晶显示 LCD display
风扇自动控制 Automatically turning off fan	双开门电梯 Through-open car
语音报站 voice announcement	

VB-病床电梯
VB- bed elevator

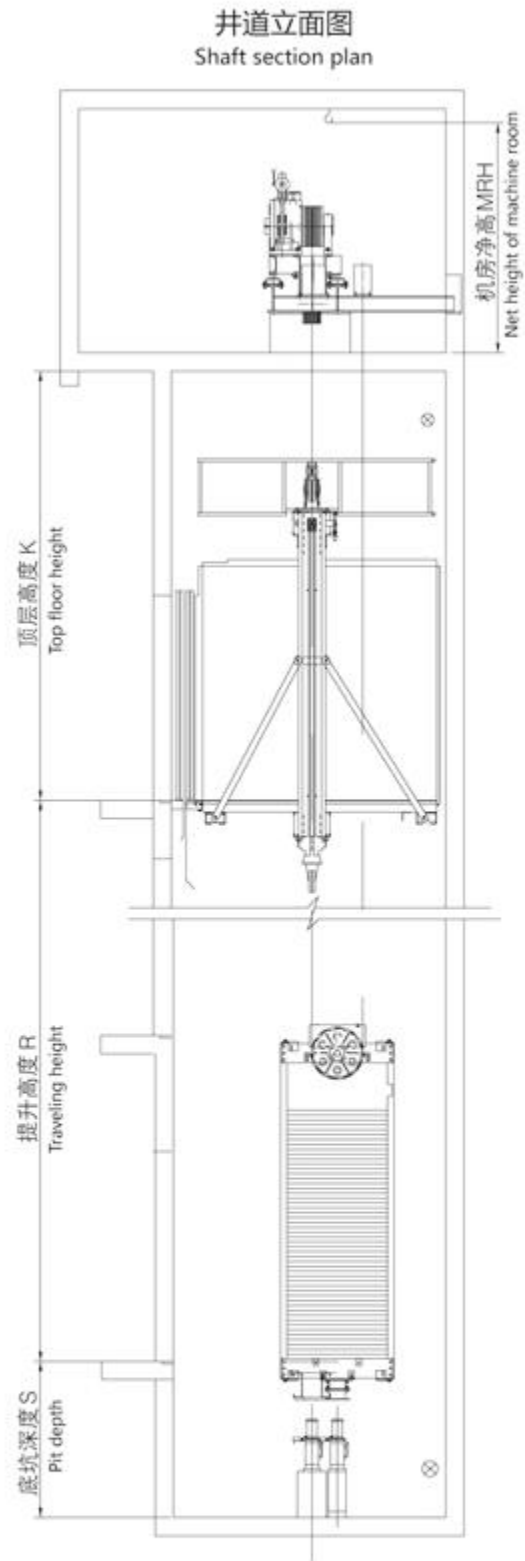
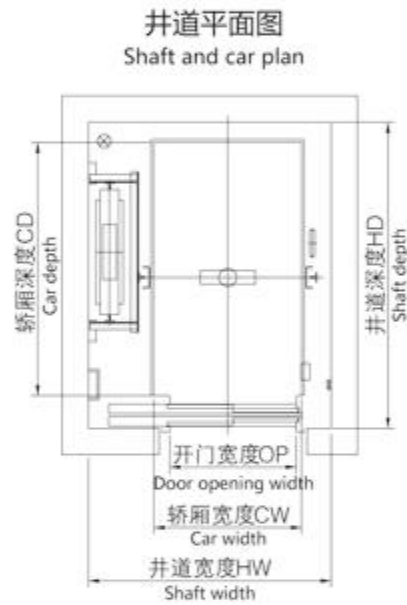

载重 Load	速度 Speed	轿厢尺寸mm Car size			开门尺寸mm Door opening size		井道尺寸mm Shaft size				最高 层站 Maximum landing	最大提升 高度m Maximum lifting height	机房净高(吊 钩以下)mm Net height of machine room
kg	m/s	CW	CD	CH	OP	OPH	HW	HD	K	S			
1600	1	1400	2400	2500	1000 (中分)	2100	2450	2850	4400	1500	20	60	2500
	1.5								4500	1600	24	72	
	1.75								4600	1600	30	90	
	2								4800	1800	40	120	
1600	1	1400	2400	2500	1200 (旁开)	2100	2300	2850	4400	1500	20	60	2500
	1.5								4500	1600	24	72	
	1.75								4600	1600	30	90	
	2								4800	1800	40	120	